



### 26PCCFA6D



*Actual product appearance may vary.*

**Pressure Sensors: Measurement Type:**  
**Gage, Vacuum Gage, Wet/Wet**  
**Differential; Signal Conditioning:**  
**Unamplified; Pressure Range:  $\pm 15.0$**   
**psi; Port Style: Straight**

#### Features

- True wet/wet differential sensing
- Lowest priced sensor with temperature compensation and calibration
- Operable after exposure to frozen conditions
- Calibrated null and span
- Temperature compensated
- Provides interchangeability
- Can be used to measure vacuum or positive pressure

#### Potential Applications

##### Medical

- Oxygen and nitrogen gas distribution in hospitals
- Dental chairs

##### Environmental

- Water control valves
- Instrumentation
- Irrigation equipment
- Filter monitoring equipment

##### Industrial Instrumentation

- Robotics
- Pressure valves
- Leak detection
- Air compressors

##### Analytical Instrumentation

- Gas chromatography

#### Description

The factory calibrated 26PC Series miniature pressure sensors provide reliable differential pressure sensing performance in a compact package. The sensor features a proven sensing technology that utilizes a specialized piezoresistive micro-machined sensing element which allows part interchangeability, high performance, reliability, and accuracy. The low power, non-amplified, non-compensated Wheatstone bridge circuit design provides inherently stable mV outputs over 1.0 psi to 250 psi sensing ranges.

Product Specifications	
Measurement Type	Wet-Wet Differential/Gage/ Vacuum Gage
Signal Conditioning	Unamplified
Pressure Range	± 15.0 psi
Maximum Overpressure	45.0 psi
Supply Voltage	10.0 Vdc typ., 16.0 Vdc max.
Compensated	Yes
Output Calibration	Yes
Response Time	1 ms max.
Termination	PCB; 1 x 4; 0.600 in
Port Style	Straight
Package Style	Honeywell - 20PC
Linearity	0.25% span typ., 0.50% span max.
Typical Sensitivity	6.67 mV/psi
Full Scale Span	100 mV typ.
Null Offset	0 mV typ.
Null Shift over Temperature	± 0.5 mV typ., ± 1.0 mV max.
Span Shift Over Temperature	± 0.75% span typ., ± 1.5% span max.
Repeatability & Hysteresis Error	± 0.20 % span typ.
Input Resistance	5.5 kOhm min., 7.5 kOhm typ., 11.5 kOhm max.
Output Resistance	1.5 kOhm min., 2.5 kOhm typ., 3.0 kOhm max.
Shock	Qualification tested to 150 g
Vibration	MIL-STD-202 Method 213 (150 g half sine 11 ms)
Weight	2 g [0.07 oz]
Operating Temperature Range	-40 °C to 85 °C [-40 °F to 185 °F]
Compensated Temperature Range	0 °C to 50 °C [32 °F to 122 °F]
Storage Temperature Range	-55 °C to 100 °C [-67 °F to 212 °F]
Media Compatibility	Limited to media which will not attack polyetherimide, silicon, flourosilicone, silicone, EPDM and neoprene seals.
UNSPSC Code	411121
UNSPSC Commodity	411121 Transducers
Availability	Global
Series Name	26PC

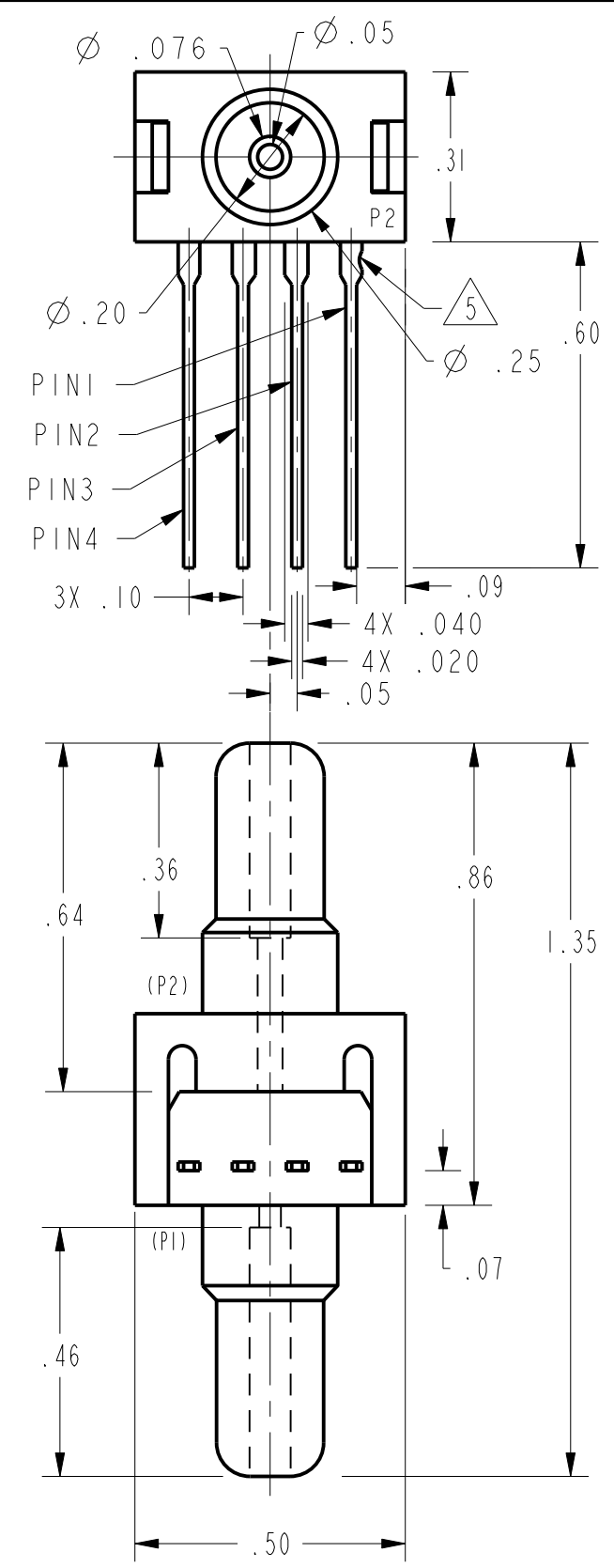

PORT A

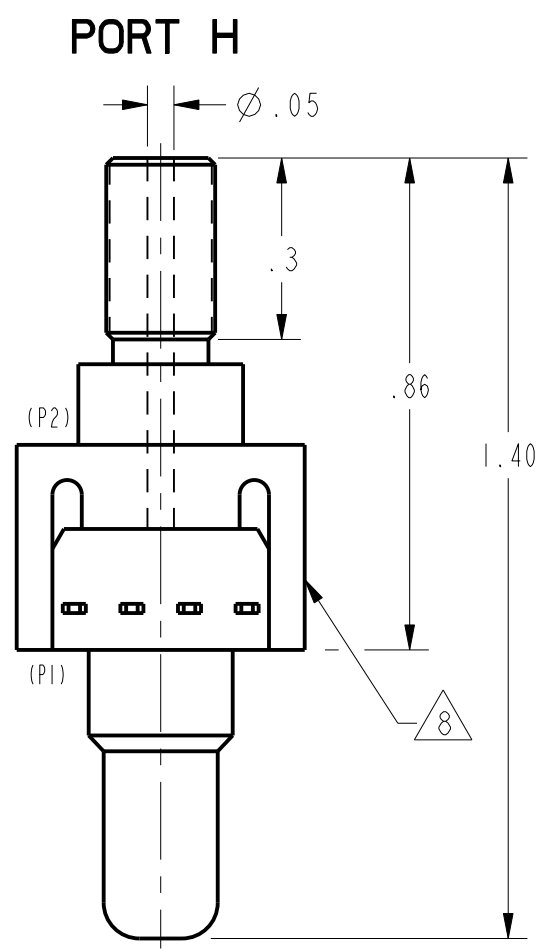

PORT H

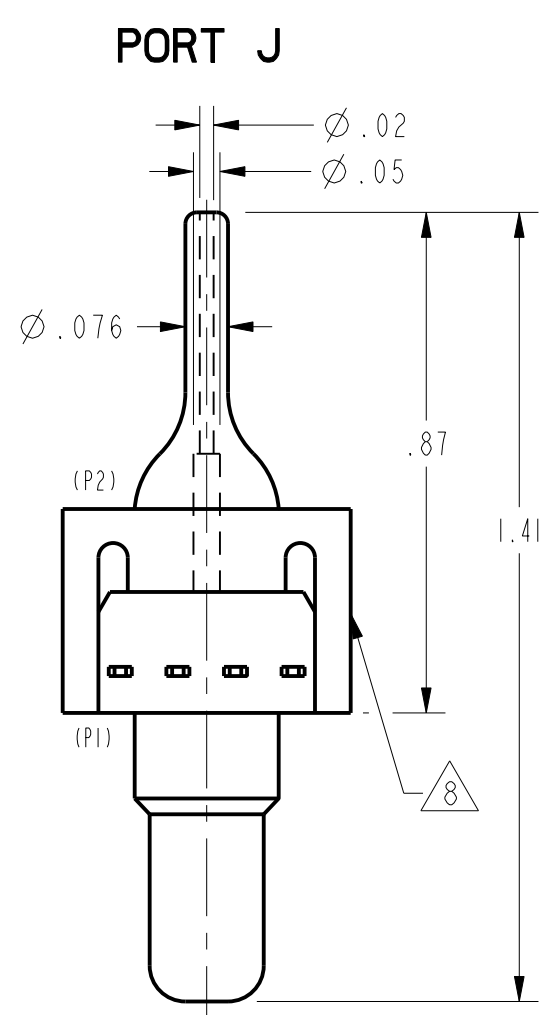

PORT J

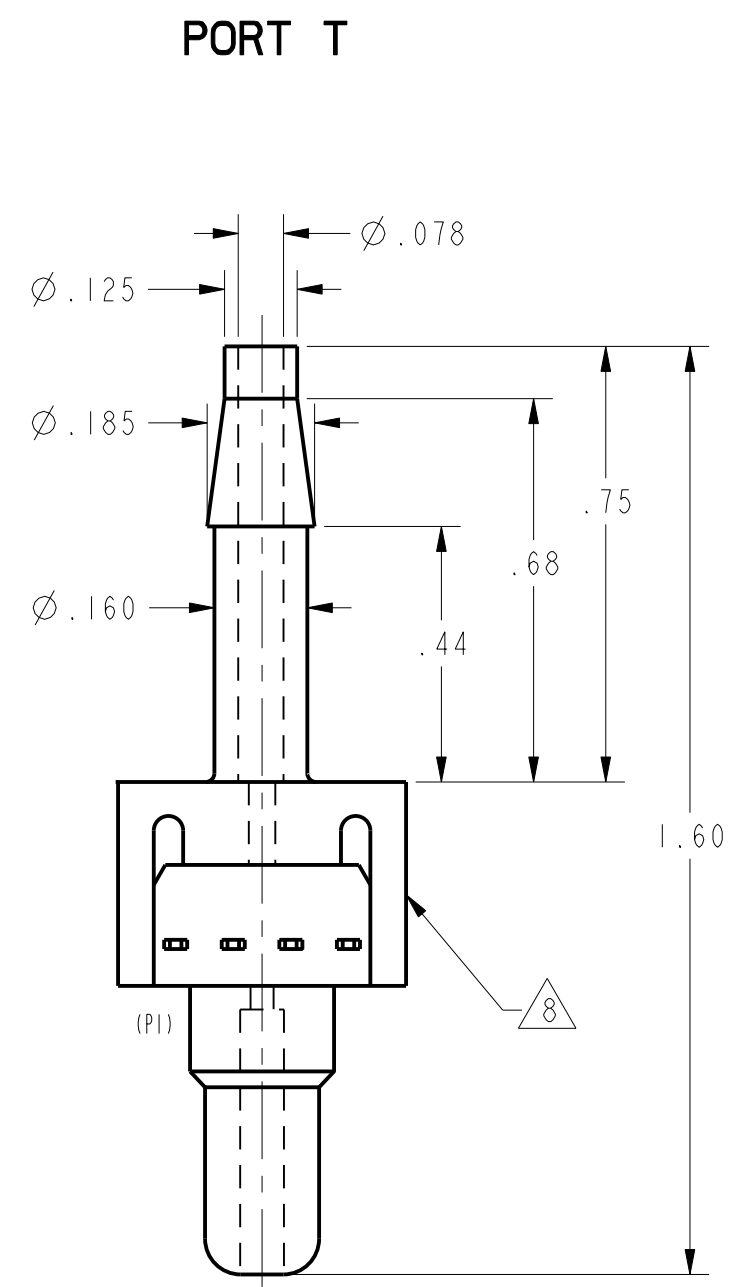

PORT T

26PC -- 6D

CATALOG LISTING	LASER BRAND / 8
26PCAF6D	6AF6D
26PCDF6D	6DF6D
26PCFF6D	6FF6D
26PCCFJ6D	6CF6D
26PCBFA6D	6BF6D
26PCCFA6D	6CF6D
26PCFNH6D	6FN6D
26PCFFT6D	6FF6D
26PCGFA6D	6GF6D
26PCGNH6D	6GN6D
26PCBVA6D	6BV6D
26PCCVA6D	6CV6D

- STYLE
- (D) DIFFERENTIAL TERMINATION
- (6) 1 X 4 (.60 IN.) PORT
- (A) STRAIGHT
- (H) 5mm THREAD
- (J) SMALL NEEDLE
- (T) LONG BARBED
- SEAL
- (F) FLUOROSILICONE
- (N) NEOPRENE (70 DURO)
- (V) VITON
- PRESSURE
- (A) 1 PSI
- (B) 5 PSI
- (C) 15 PSI
- (D) 30 PSI
- (F) 100 PSI
- (G) 250 PSI

METRIC	INCHES
0.41	.016
0.51	.020
1.02	.040
1.3	.05
1.8	.07
1.93	.076
1.98	.078
2.0	.08
2.3	.09
2.5	.10
3.18	.125
4.06	.160
4.70	.185
5.1	.20
6.4	.25
7.9	.31
9.1	.36
11.2	.44
11.7	.46
12.7	.50
15.3	.60
16.5	.64
17.3	.68
19.1	.75
21.8	.86
22.1	.87
34.3	1.35
35.6	1.40
35.8	1.41
40.6	1.60

PRESSURE RANGE (PSI)	0 - 1		0 - 5		0 - 15		0 - 30		0 - 100		0-250		UNITS								
	MIN	NOM	MAX	MIN	NOM	MAX	MIN	NOM	MAX	MIN	NOM	MAX									
SPAN (P2>P1) / 1	14.7	16.7	18.7	47	50	53	97	100	103	95	100	103	95	100	105	143	150	157	mV		
NULL OFFSET	-1.5	0	+1.5	-1.5	0	+1.5	-1.5	0	+1.5	-1.5	0	+1.5	-2.0	0	+2.0	-2.0	0	+2.0	mV		
LINEARITY (BFSL, P2>P1)	TYP		MAX	TYP		MAX	TYP		MAX	TYP		MAX	TYP		MAX	TYP		MAX	UNITS		
NULL SHIFT (0 TO 25 °C, 25 TO 50 °C) / 2	±0.5		±1.0	±0.5		±1.0	±0.5		±1.0	±0.75		±1.5	±0.5		±1.0	±2.0		±1.0	±2.0	mV	
SPAN SHIFT (0 TO 25 °C, 25 TO 50 °C) P2>P1 / 2	±1.0		±2.0	±1.0		±1.5	±0.75		±1.5	±0.5		±1.5	±0.5		±1.5	±0.5		±1.5	±0.5	±1.5	%SPAN
REPEATABILITY AND HYSTERESIS	±0.5		±2.0	±0.2		±0.2	±0.2		±0.2	±0.2		±0.2	±0.2		±0.2	±0.2		±0.2	±0.2	%SPAN	
OVERPRESSURE (P2>P1; P1>P2)			20			20			45			60			200			500	PSI		
ALL PRESSURE RANGES	MIN	NOM	MAX	UNITS																	
EXCITATION VOLTAGE			10	16		VDC															
INPUT RESISTANCE			5.5K	7.5K		1.5K OHMS															
OUTPUT RESISTANCE			1.5K	2.5K		3.0K OHMS															
RESPONSE TIME					1.0 ms																
TEMPERATURE RANGES																					
STORAGE	-55 °C TO +100 °C (-67°F TO +212°F)																				
OPERATE	-40 °C TO +85 °C (-40°F TO +185°F)																				
COMPENSATED	0 TO +50 °C (+32 °F TO +122 °F)																				

- NOTES
- SPAN IS THE ALGEBRAIC DIFFERENCE BETWEEN OUTPUT AT MAXIMUM RATED OPERATING PRESSURE AND OUTPUT AT 0 PSI
  - TEMPERATURE ERROR IS CALCULATED WITH RESPECT TO 25 °C
  - INPUT MEDIA LIMITED ONLY TO THOSE MATERIALS THAT WILL NOT ATTACK SILICON, THE HOUSING MATERIAL OR SEAL MATERIAL
  - TERMINALS ARE PLATED FOR SOLDERING (LIMIT SOLDERING TO 315 °C FOR 10 SECONDS MAXIMUM)
  - PIN 1 IS IDENTIFIED BY NOTCH IN LEAD
  - SENSOR IS OPERATIONAL OVER VACUUM PRESSURE RANGE
  - RATIOMETRIC TO SUPPLY VOLTAGE
  - CATALOG LISTING AND DATE CODE HERE. ALTERNATE FORMAT OF CATALOG LISTING BRAND IS THE ENTIRE CATALOG LISTING

CIRCUIT DIAGRAM

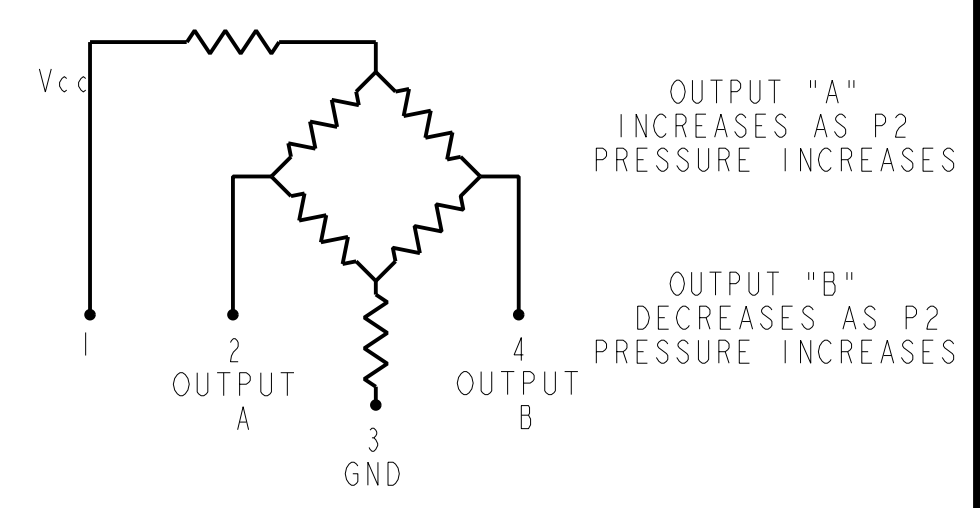

THIRD ANGLE PROJECTION
SCALE 3 : 1
DO NOT SCALE PRINT
UNLESS OTHERWISE SPECIFIED TOLERANCES ARE
ONE PLACE (.0) +.030
TWO PLACE (.00) +.015
THREE PLACE (.000) +.005
ANGLES °
WEIGHT 2.0Z

THIS DRAWING COVERS A PROPRIETARY ITEM AND IS THE PROPERTY OF MICRO SWITCH, A DIVISION OF HONEYWELL. THIS DRAWING IS NOT TO BE COPIED OR USED WITHOUT THE APPROVAL OF MICRO SWITCH.

FED. MFG. CODE 91929

**MICRO SWITCH**  
a Honeywell Division

**BRIDGE PRESSURE SENSOR**

**26PC SERIES CHART 4**